



The Impact of Gold, Oil Prices, and their Associated Implied Volatilities on Performance of Pakistan's Stock Market

Azeem Akhtar Bhatti¹, Mansoor Ali Jamali², Maryam Khokhar³, Muhammad Haneef Buriro⁴

¹ Assistant Professor, Department of Commerce, Sindh University Laar Campus Badin, Pakistan.

Email: azeem.bhatti@usindh.edu.pk

² M.Phil. Scholar, Muhammad Ali Jinnah University Karachi, Pakistan. Email: ajmansoor5@gmail.com

³ Assistant Professor, Department of Business Studies, Bahria Business School, Bahria University Karachi Campus, Karachi, Pakistan. Email: maryamkhokhar60@gmail.com

⁴ M.Phil. Scholar, Muhammad Ali Jinnah University Karachi, Pakistan. Email: mhaneefburiro@gmail.com

ARTICLE INFO

ABSTRACT

Article History:

Received: March 21, 2023
Revised: April 13, 2023
Accepted: April 13, 2023
Available Online: June 13, 2023

Keywords:

Pakistan Stock Exchange
Oil Prices
Gold Price
Interest Rate
Exchange Rate

Funding:

This research received no specific grant from any funding agency in the public, commercial, or not-for-profit sectors.

This study examined the asymmetrical implications of gold and oil prices, as well as the implied volatility that goes along with them, on the performance of Pakistan's stock market. It was used Chicago Board of Options Exchange's GVZ and OVX index for measuring volatility in gold market and oil market respectively due to more uncertainty in commodity markets and also took historical price movements, investor's expectations regarding global prices into account. The monthly data used from October 2009 to January 2023. An ARDL approach was employed for checking short term and long term asymmetrical. The results of ARDL revealed that oil volatility index have significant impact of Pakistan's stock market in short-run and long-run. The Gold Volatility Index shows significant impact after one month on both stock market capitalization and KSE 100 indexes in the short run. Fluctuations in worldwide commodity prices have a significant influence on underdeveloped economies like Pakistan and have a negative effect on the entire economy. The volatility and fluctuations in oil prices lead to higher production costs, which create uncertainty in companies' cash flows.

© 2023 The Authors, Published by iRASD. This is an Open Access article distributed under the terms of the Creative Commons Attribution Non-Commercial License

Corresponding Author's Email: maryamkhokhar60@gmail.com

1. Introduction

The stock market is considered the backbone of an economy. It is not just to allow investors to earn profit but also helps conglomerates to finance their projects, products, and services for increasing productivity which leads to economic development (Khan & Khan, 2018). Ndlovu, Faisa, Resatoglu, and Türsoy (2018) explained that the stock market in their book named Fundamentals of Corporate Finance as "market in which previously issued securities are traded among investors. "People can invest their extra money in the stock market to make meaningful gains and profits, which makes it crucial for the growth and development of the economy (Irshad et al., 2019). The stock markets in emerging economies demonstrate prompt progress in form of value and volume from last few decades. Thus, there has been a considerable inflow of capital and investment possibilities from developing economies to emerging ones. On the other side, global news and events cause erratic swings in developing country equities (Raza, Shahzad, Tiwari, & Shahbaz, 2016). Varieties of macro level elements, including those that are economic, social, political, as well as other local and international aspects, have an impact on the performance of stock markets, regardless of whether they occur in developed or emerging economies. Macroeconomic factors such as exchange rates, inflation, interest rates, crude oil prices, gold prices have more impacts on performance of stocks. For investors, after stocks, bonds, and mutual funds, Second Avenue for investment is the commodity market such as oil and gold where they can earn profits.

Since few years, Pakistan has been dealing with a number of basic risk variables, including interest rates, inflation, rupee value, and oil prices. The Pakistani financial system has been noted as being unable to adapt to the full financial crisis (Khaskhelly et al., 2022). The stock market is significantly impacted by changes in gold prices on a global scale. To avoid potential stock losses in such circumstances, investors frequently switch their investments from equities to gold bars. In addition to gold prices, the historical variations in world oil prices show that there will be significant price volatility in oil prices globally. The relationship between stock markets and crude oil prices has both disturbed and enhanced by the world crisis of 2007 and 2008 (Khokhar, Hou, Rafique, & Iqbal, 2020).

1.1. Gold Prices and Gold Volatility

Gold is the most prominent factor for human economic development, and it is considered as sign of wealth, nobility, and prosperity. The several metals, including gold, were served as a medium of exchange throughout the world (Qasim, Iqbal, Hassan, & Ali, 2021). In times of unrest, gold is regarded as a safe haven for stock markets, a financial asset, a medium of trade, and a hedge against inflation (Baur & Lucey, 2010). Because of its affordability, gold is a popular alternative investment that offers investors security during economic downturns (Hou, Khokhar, Zia, & Sharma, 2022). Due to its low correlation with other assets, gold maintains its purchasing power during inflationary periods and aids investors in lowering overall portfolio risk (Raza et al., 2016).

1.2. Oil Prices and Oil Volatility

Different industry expenses and stock market prices are significantly influenced by oil prices. Every sector of the economy is impacted by oil prices, either directly or indirectly (Demir, 2019). Increase in cost of oil influences the earnings of the industry which directly impacts the overall economy. Oil being important for economic development, volatilities in oil prices is major concern for oil importing economies as most of the countries do not have sufficient resources (Khokhar et al., 2020). Oil is crucial for economic growth, so volatility in oil prices is a major concern for oil-importing economies because the majority of nations lack the necessary resource (Vveinhardt, Streimikiene, Ahmed, Ghauri, & Ashraf, 2017). The effects of crude oil prices are intense on economic conditions of countries across the world. As opposed to industrialized economies, emerging and developing economies are directly impacted by changes in crude oil prices, which are directly linked to stock markets (Khokhar, Devi, Siddiqui, & Bhatti, 2022).

1.3. Foreign Exchange Rate and Interest Rate

The role of interest rate is dynamic on stock price fluctuations (Chang et al., 2019). Changes in interest rates have an impact on people's investment decisions, which is a significant economic determinant (Yumei, Iqbal, Irfan, & Fatima, 2021). On the other hand, the business community borrows money from financial institutions to boost production (Misra, 2018). Individuals also seek to borrow from financial institutions at prevailing interest rates and invest in stocks (Hailiang, Chau, & Waqas, 2023). When interest rates are high, investors will shift their investment from the stock market and deposit in financial institutions who offer higher rates of return. This scenario will impact performance of stock market which will directly impact whole economy (Omodero & Mlanga, 2019).

1.4. Research Problem

The stock market is considered an important economic indicator just like GDP and other indicators. However, fluctuations and uncertainties discourage savings so that investors are not sure they will earn or even get back their original investment back. These uncertainties arise from fluctuations in macro level factors such as rates of interest, exchange, and inflation. Unfortunately, Pakistan is facing number of economic and non-economic issues since few decades and one of them is the prices of oil. Since Pakistan is an oil-importing nation, rising oil prices have an impact on the cost of every good or service, which in turn affects consumer spending, disposable income, and investment decisions (Mothafar, Zhang, & Al-Maqrami, 2022). In addition, increase in crude oil prices surges the cost of production that affects the sales, profitability, stock returns of multiple sectors of an economy and then investors lose their confidence, and they avoid investing in stock market. Therefore, the present situation of Pakistan where crude oil prices is increasing, depreciation of local currency, increasing gold prices, and inflation are weakening the confidence of investors.

1.5. Research Gap

Numerous research has been conducted to determine the impacts of conventional measures of commodity market such as prices of gold and oil on performance of stock markets. Recently, interest in using Chicago Board of Options Exchange's oil volatility index (OVX) and gold volatility index (GVZ) by scholars has been increased. Looking at and GVZ are the forward-looking measures of volatility in oil and gold markets respectively. These implied volatilities are regarded as more accurate measure of uncertainty in commodity markets because these proxies take historical price movements, investor's expectations regarding global prices into account as well as track investor sentiments (Boateng, Adam, & Junior, 2021). However, there exists a gap in previous literature in context of Pakistan, which this study intends to fill. In addition to oil and gold prices, this research will determine the impacts of oil and gold price implied volatilities on performance of Pakistan's stock market (Hou et al., 2022).

1.6. Research Objectives

- To find out both the short- and long-run effects of implied volatilities of oil and gold markets on performance of Pakistan's stock market.
- To evaluate the short- and long-run effects of impact of international gold and oil prices on Pakistan's stock market.

1.7. Research Questions

1. Does implied volatility in the oil and gold markets have a long-term or short-term impact on how Pakistan's stock market performs?
2. Does it look into the short- and long-term effects of global oil and gold prices on Pakistan's stock market?

1.8. Importance of Research

The stock market is an important macro-economic indicator and performance of stock market is very crucial for all emerging and developed nations. Through stock markets, people invest their savings and earn reasonable profits for survival. Pakistan is an emerging country, thus macroeconomic indicators that are volatile present challenges to both investors and policymakers. For an emerging and oil importing country like Pakistan, oil acts as an input for industrial products and run day-to-day activities. However, rising oil prices and volatilities at international level increases the prices and create inflation, which is alarming investors and policy makers to take serious actions to control inflation and other problems. In order to avoid or reduced risk, investors look for other investment opportunities and one of them is the gold market. Gold can act as a portfolio diversifier for investors in inflationary conditions. However, volatilities in gold prices have direct impact on the investment decisions and create uncertainty for investors.

This study will help individual investors and fund managers in developing risk management strategies in order to maximize returns and reduce risk associate with their investments and portfolios. Investors and fund managers will be able to better predict future stock market trends by looking and international crude oil and gold market. By looking at implied volatilities oil and gold prices, investors and fund managers will be able to know when to increase or reduce investment in stocks and invest in other alternative investments such as gold. In addition to investors and fund managers, this research will help policy makers. Policy makers will be able to take develop strategies to balance the oil, gold price volatilities and stock market performance and economic conditions.

1.9. Limitations of the Study

The empirical results reported in this study should be considered in the light of following limitations.

- The time period covered by this study is from 2009 to 2023 as data for two variables that are oil volatility index (OVX) and gold volatility index (GVZ) were not available.
- The volatility index of oil and gold does not reflect historical price movements only but they take future expectations of investors into consideration as well.
- The proxy used for interest rate is weighted average of fresh deposits which does not include deposits kept by banks as security for letters of guarantee and credits have been

referred to as margin. In addition, Deposits made in foreign currencies are exchanged for rupees using the current interbank rates as of the last day of the reporting month.

2. Literature Review

2.1. Theoretical Overview

Casson and Giusta (2007) Developed the theory that is "The Arbitrage Pricing Theory" and argued that stock market returns can predicted by studying the linear relationship of stock market returns with various macroeconomic factors. The systemic risk that is represented by these macroeconomic factors is diversifiable, affects the entire market, and is not restricted to a single asset (Mollick & Nguyen, 2015) examined that the relationship between stock returns, oil price returns and exchange rate index in their study by applying the arbitrage pricing model and found that the positive impact of oil prices on stock returns of oil and gas sector (Ahmed et al., 2022) there are multiple channels by which behavior of stock market altered by oil prices (Degiannakis, Filis, & Arora, 2018). The oil acts as a basic input for different sectors of the economy and the changing oil prices will definitely affect the productions cost and thus the profit margins and future cash flows will change. Secondly, the stock markets are influenced by oil prices through monetary channels or interest and inflation rates (Khokhar et al., 2022).

2.2. Empirical Review

2.2.1. Stock Market and Oil Prices:

Numerous papers have considered the affiliation of oil price with stock markets. The research study was conducted in 2019 to test the long-run relationship between oil prices and stock market in Mexico by (Singhal, Choudhary, & Biswal, 2019) using daily time series data from the period of January 2006 to April 2018. It is applied ARDL bound test of con-integration and found negative association between oil prices and stock market, Moreover, to find out the leverage effects of gold, oil, dollar rates on volatility of stock market in India, (Aravind, 2018) analyzed daily data from first month of 2012 to last month of 2016 and their results confirmed that the stock market performed better than oil market over the studied period of time. In addition, the volatility in stock market of India is influenced by the fluctuations in oil rates and stock prices are affected by crude oil prices (Khokhar et al., 2022). Hung (2020) examined that the time and frequency are not connected between oil markets and stock markets in Hungry, by using econometric models like DCC-GARCH and wavelet coherence analysis. Their results revealed that the higher correlations between Budapest stock market and crude oil prices (Khaskhelly et al., 2022). It was confirmed that commodity markets like crude oil have significant impact on stock market of Hungry in short-run. However, in long run crude oil markets are affected by stock markets. Arfaoui and Ben Rejeb (2017) examined the linkage amid gold, oil, foreign exchange, and stock market in global perspective by employing data from 1995 to 2015.

H₁: The global prices of oil have negative impact on stock market of Pakistan.

2.2.2. Stock Market and Oil Volatility Index

Previous research study on oil-stock relationship has shown that instability in price of oil globally is critical for importing and exporting economies of oil (Joo & Park, 2021). Syed and Bouri (2022) studied the volatility in oil prices in relation to the fluctuation of the oil and stock markets importing and exporting nations by using multivariate GARCH models and spillover index of (Siddiqui et al., 2023). Thus, results revealed that spillovers from volatility in prices of oil are relatively high for developing countries. Furthermore, spillovers from oil price volatility to stock markets are high for exporters in both developed and developing countries (Irshad et al., 2019). In addition, the financial crises do not change the dynamics of spillovers in both developed and developing countries. To study the relationship among oil markets of United States and South Korea and uncertainty in stocks, (Choi & Hong, 2020) tried to assess causal relationship among oil and stock market index volatilities with the help of Toda-Yamamoto granger causality tests for three sub-periods and autoregressive distributed lag bounds. One more work of stock market volatilities that took KOSPI 200 and S&P 500 volatilities (Benlagha, 2020). Thus, results of ARDL model demonstrated that there exists a long run association between stock market volatility and the oil market. For the whole sample period, they found bi-directional causality between oil volatility index and stock volatility index (Irshad et al., 2019). In addition, they confirmed the association between oil volatility index and KOSPI is changed with time.

H₂: The Oil Volatility Index (OVX) has negative impact on Pakistan stock market.

2.2.3. Stock Market and Gold Prices

The existing literature has emphasized that gold can be useful for hedging against stock market risks. Aravind (2018) concluded in his research work by using daily observations from January 2012 to December of 2016 with a purpose to identify the leverage effects of gold, oil, and dollar rates on NIFTY. To check the impact of oil prices and oil price volatilities on stock market of developing countries, (Raza et al., 2016) used monthly data covering time period from January 2008 to June 2015. Impact or to check the long and short-run asymmetries, the nonlinear ARDL model was applied and the impact of prices of gold on stock markets found nonlinear in short as well as in long-term. The results revealed that price of gold have positive and significant impact on prices of stocks. Bhuyan and Dash (2018) investment in gold can safeguard the short-term extreme shocks of stock market. They employed impulse response function and Johnson's co-integration, Granger causality based on VAR framework on monthly data from 2001 to 2017 to test the casual connection between gold prices and stock market returns in India (Waseem, Khokhar, Zia, & Hou). The results of Johnson's co-integration confirmed the long-run relationship between gold and stock market returns, whereas Granger causality approach found no short-run relationship between gold price and stock market return. They determined that gold is the safe avenue for investors of Indian stock market (Hou, Khokhar, Sharma, Sarkar, & Hossain, 2023).

H₃: The global gold prices negatively impact stock market in Pakistan.

2.2.4. Stock Market and Gold Volatility Index

Masih, Rajasekaran, Saini, and Kaur (2021) studied that the effects of gold volatility index on United States by using frequency approach of spillover index method of Diebold and Yilmaz (2012) and on daily data. The results demonstrated that gold volatility index (GVZ) has a low spillover impact on sectorial returns of United States which suggests that gold can be used to diversify the risk of ten included stock market sectors (Khokhar, Hou, Sethar, Amin, & Shakib, 2019). In 2020, a study conducted by (Alqahtani & Chevallier, 2020) to check dynamic spillover between gold volatility and stock returns of member countries of Gulf Cooperation Council and it is applied DCC-GARCH models to determine conditional correlations by using weekly data from July 2004 to September 2018 (Yumei et al., 2021). Their results confirmed that stock returns of GCC countries are negatively correlated with gold volatility index and the level of this correlation found higher in the period of crisis. Among all GCC member countries, Saudi Arabia and Qatar found most sensitive to oil shocks, and Bahrain's stock market was less influenced by oil volatility. To examine the relationship of stock markets of China, India, Turkey, Mexico, Russia, and Indonesia with gold volatility index, (Usman & Siddiqui, 2019) employed daily data from March 2010 to February 2018

H₄: The Gold Price Volatility (GVZ) negatively impact Pakistan stock market.

2.2.5. Stock Market and Exchange Rate

The significance of the exchange rate with the stock market has been acknowledged in earlier literature. In 2018, a study was carried out by (Aravind, 2018) to examine the leverage effect of US dollar rate on Indian stock market by applying GARCH model on daily data from the month of January 2012 to December 2016. They analyzed before, after the crisis, and the overall time period from April 2003 to May 2020 (Mothafar et al., 2022). It was found that positive shocks of currency value have no impact on stock indexes of Bombay stock index and the relationship between stock indexes and exchange rate was found asymmetrical. However, in the long term and after the crisis the negatives shocks to currency value remain insignificant.

H₅: Exchange rate negatively impact Pakistan's stock market.

2.2.6. Stock Market and Interest Rate

Misra (2018) conducted a study to examine the link between BSE Sensex and macroeconomic factors including interest rate. Quarterly time series data from April 1999 to March 2017 was collected. The Johnson Co integration was applied for checking long-run causality and Wald test for checking short-run association ship between variables. They found negative significant long-run causality between stock BSE Sensex and interest rate. However, no short-run causality was found between BSE Sensex and interest rate. A study was conducted by (Khan & Khan, 2018) to examine the effects of different macroeconomic variables on Karachi Stock

Exchange, applied ARDL model to check short-term and long-term results on monthly data from May 2000 to August of 2016 (Siddiqui et al., 2023). The results revealed that the integration between interest rate and a stock price is insignificant. However, in the long-term, the integration between interest rate and stock prices found significant. To check the effects of macroeconomic variables on stock market fluctuations.

H₆: Interest rate have negative impact on Pakistan’s stock market.

3. Conceptual Framework

Figure 1: Conceptual Framework Impact of Gold, Oil Prices, OVX, GVZ, Interest Rate and Exchange Rate of PSX

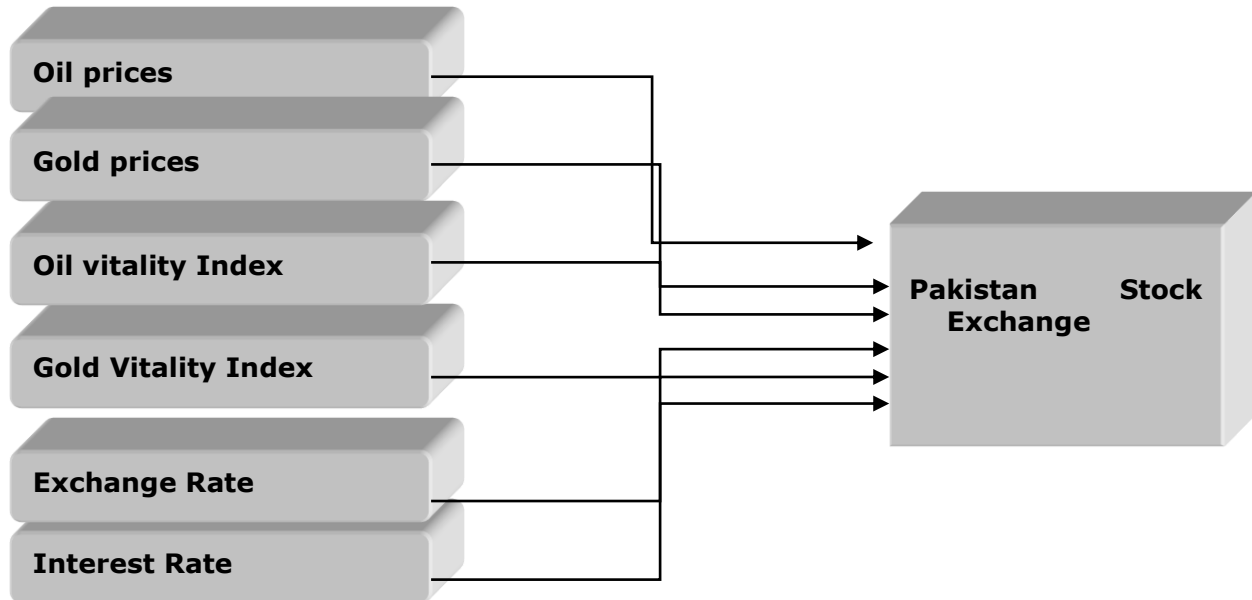

4. Methodology

4.1. Research Design

The research onion says that the deductive technique is ideal for this study since hypotheses are established on the basis of theoretical and empirical examination. The study is quantitative in nature and the data obtained is expressed in numbers to evaluate the hypothesis.

4.2. Secondary Data Source

The values of variables which are shown in the above theoretical framework from October 2009 to January 2023 have been collected from investing.com, ceicdata.com, PSE and SBP.

Table 1: Variable Description

Variable	Description
MCAP	All shares Market Capitalization in Pakistani rupees
KSE	Karachi Stock Exchange 100 Index points
OP	WTI crude oil spot prices in USD
GP	Spot price of one troy ounce of gold in USD
OVX	CBOE Crude Oil Volatility Index
GVZ	CBOE Gold Volatility Index
EXR	Value of USD in Pakistani rupee
INR	Rate of interest offered by banks in Pakistan to depositors

4.2.1. ARDL Equation1

$$\begin{aligned}
 LnMCAP = & \alpha_0 + \sum_{i=1}^p \alpha_1 \Delta LnMCAP_{t-i} \\
 & + \sum_{i=0}^q \alpha_2 \Delta LnGP_{t-i} + \sum_{i=0}^q \alpha_3 \Delta LnOP_{t-i} + \sum_{i=0}^q \alpha_4 \Delta LnOVX_{t-i} + \sum_{i=0}^q \alpha_5 \Delta LnGVZ_{t-i} + \sum_{i=0}^q \alpha_6 \Delta LnEXR_{t-i} + \sum_{i=0}^q \alpha_7 \Delta LnINT_{t-i} \\
 & + \rho LnMCAP_{t-1} + \varphi_1 LnGP_{t-1} + \varphi_2 LnOP_{t-1} + \varphi_3 LnOVX_{t-1} + \varphi_4 LnOVZ_{t-1} + \varphi_5 LnEXR_{t-1} + \varphi_6 LnINT_{t-1} + u_t
 \end{aligned}$$

4.1.2. ARDL Equation 2

$$\begin{aligned} \text{LnKSE} = & \alpha_0 + \sum_{i=1}^p \alpha_1 \Delta \text{LnKSE}_{t-1} \\ & + \sum_{i=0}^q \alpha_2 \Delta \text{LnGP}_{t-i} + \sum_{i=0}^q \alpha_3 \Delta \text{LnOP}_{t-i} + \sum_{i=0}^q \alpha_4 \Delta \text{LnOVX}_{t-i} + \sum_{i=0}^q \alpha_5 \Delta \text{LnGVZ}_{t-i} + \sum_{i=0}^q \alpha_6 \Delta \text{LnEXR}_{t-i} + \sum_{i=0}^q \alpha_7 \Delta \text{LnINT}_{t-i} \\ & + \rho \text{LnKSE}_{t-1} + \varphi_1 \text{LnGP}_{t-1} + \varphi_2 \text{LnOP}_{t-1} + \varphi_3 \text{LnOVX}_{t-1} + \varphi_4 \text{LnOVZ}_{t-1} + \varphi_5 \text{LnEXR}_{t-1} + \varphi_6 \text{LnINT}_{t-1} + u_t \end{aligned}$$

5. Analysis and Discussions

5.1 Unit Root Test

The Unit Root Test is the one of the methods to check the stationary of data series. When a series' mean, variance, and auto covariance remain constant throughout time and there is no predictable pattern in the data, the series is said to be stationary. For regression analysis, we test stationary because if data has a trend or series is non-stationary and the results of regression will be spurious meaning that the results do not make any sense. To convert series from non-stationary to stationary, the method of differencing is used to get reliable regression results. Below are the results of Augmented-Dickey-Fuller (ADF) unit root test at level and 1st difference and results verify that all of the variables are level and stationary. While all other variables are discovered to be stationary at the first difference, only two variables, GVZ and OVX, are stationary at level.

Table 2: Unit Root Test

Variables	Level		1st Difference	
	C	C&T	C	C&T
MCAP	0.6565	0.8775	0.0000	0.0000
KSE100	0.6818	0.8515	0.0000	0.0000
GP	0.3878	0.6260	0.0000	0.0000
OP	0.2211	0.6561	0.0000	0.0000
GVZ	0.0003	0.0015	0.0000	0.0000
OVX	0.0000	0.0001	0.0000	0.0000
EXR	0.9976	0.9436	0.0000	0.0000
INT	0.3743	0.8440	0.0000	0.0000

5.2 The Lag Length Selection Criteria for ARDL Model

If it is shown that each variable is level in stationary. Thus, before proceeding to ensure that the results are accurate, an autoregressive distributed lag (ARDL) model must be used to examine the long- and short-term effects of independent variables on the choice of lag length for the dependent variable. The results of multiple criteria for selection of number of lags are given in table 3.

Table 3: Determining the Lag Length – Model 1

	Lag 4	Lag 3	Lag 2	Lag 1
Akaike info criterion	-3.263078	-3.264739*	-2.987185	-2.832361
Schwarz criterion	-2.990547*	-2.972741	-2.696432	-2.658649
Hannan-Quinn criterion	-3.152394*	-3.146148	-2.869107	-2.761818

The results of table 3 showed that the three different criteria for selection of lag length for ARDL model taking MCAP as a dependent variable. Based on Akaike information criterion, the optimal numbers of lags are 3 whereas Schwarz criterion and Hannan-Quinn criterion both suggest optimal lags are 4.

Table 4: Determining the Lag Length – Model 2

	Lag 4	Lag 3	Lag 2	Lag 1
Akaike info criterion	-3.161254*	-3.103656	-2.835734	-2.667935
Schwarz criterion	-2.711596	-2.772725*	-2.486830	-2.494224
Hannan-Quinn criterion	-2.978622*	-2.969254	-2.694040	-2.597393

Table 4 exhibits the values of Akaike, Schwarz, and Hanna-Quinn criterion for optimal number of lags by taking KSE 100 index as a dependent variable in ARDL model. The values of

Akaike information criterion and Hannan-Quinn criterion suggest optimal lags are 4 whereas based on Schwarz criterion optimal lags are 3.

5.3 ARDL Model Short-Run Results

After confirmation that all the variables are stationary at level and number of optimal lags are decided then its ensure to move Autoregressive Distributed (ARDL) Model and further more (Shrestha & Bhatta, 2018) described that the ARDL model is also useful in determining the long-run and short-run effects of multiple independent variables on the dependent variable when the unit root test reveals mixed results. Below are the results of ARDL model in which MCAP is the dependent variable whereas GP, OP, GVZ, OVX, EXR, and INT are regressors in the model. The numbers of lags selected are three based on Akaike Info Criteria (AIC) and sample contains monthly observations from October 2008 to January 2022.

Table 5: ARDL Short-Run Results – Model 1

Dependent Variable: D_MCAP_LN				
Undependable	Co-efficient	Norm Error	T-Value	P.*
D_MCAP_LN(-1)	0.067064	0.064437	1.040766	0.2998
D_MCAP_LN(-2)	-0.107269	0.061855	-1.734194	0.0851
D_MCAP_LN(-3)	-0.092630	0.060830	-1.522770	0.1300
D_GP	-8.75E-06	5.63E-05	-0.155376	0.8767
GVZ	-0.000417	0.001336	-0.312124	0.7554
GVZ(-1)	0.003361	0.001643	2.045199	0.0427
GVZ(-2)	-0.001751	0.001220	-1.435106	0.1535
D_OP	0.000254	0.000682	0.371767	0.7106
OVX	-0.001350	0.000375	-3.603916	0.0004
OVX(-1)	0.000591	0.000380	1.554177	0.1224
D_EXR	-0.003113	0.001596	-1.950784	0.0531
D_INT	-0.001856	0.008918	-0.208143	0.8354
D_INT(-1)	-0.000316	0.008541	-0.037022	0.9705
D_INT(-2)	-0.034913	0.008732	-3.998464	0.0001
C	0.017514	0.015759	1.111367	0.2683
R ²	0.342134	F-value		5.274950
R ² Adjusted	0.277274	P-(F-value)		0.000000
D-W stat	2.170653			

The short-run outcomes from employing monthly time series data from October 2009 to January 2023 with the ARDL model are shown in Table 5. The coefficients of lagged values of MCAP found insignificant at % percent significance level in short-run. Impact of current value of GP and GVZ found insignificant on MCAP. However, impact of GVZ reflects MCAP after one month as the one period lagged value of GVZ has significance impact on MCAP. In short-run, the current value of OP has no significant impact on MCAP but coefficient of OVX found significant and positive. One period lagged value of OVX went insignificant meaning that value of previous month's OVX has no impact on MCAP. Above results are showing that current value EXR has insignia impact on MCAP as the value of probability is just above 5 percent whereas current and one-month previous value of INT has insignificant impact of MCAP, but INT becomes significant after two month and negatively impact MCAP. The ARDL short-run results is showing the value of Adjusted R-squared is 27.27 which means that 27.27% change in Pakistan stock market capitalization is caused by all above selected variables in this study. The value of Durbin-Watson stat 2.1706 indicates that the serial correlation issue is not present in the model. Given that the probability value of the F-statistic is zero, the probability value of the F-statistic indicates the model's overall goodness of fit.

Table 6: ARDL Short-Run Results – Model 2

Dependent Variable: D_KSE_LN				
Undependable	Co-efficient	Norm Error	T-Value	P.*
D_KSE_LN(-1)	-0.112666	0.075767	-1.487007	0.1394
D_KSE_LN(-2)	-0.113912	0.064866	-1.756102	0.0814
D_KSE_LN(-3)	-0.150567	0.062712	-2.400923	0.0177
D_GP	-4.21E-05	5.85E-05	-0.720306	0.4726
GVZ	-0.000811	0.001397	-0.580944	0.5623
GVZ(-1)	0.002901	0.001384	2.096258	0.0380
D_OP	-0.000364	0.000770	-0.472437	0.6374
D_OP(-1)	-0.000436	0.000763	-0.571246	0.5688
D_OP(-2)	-0.000312	0.000773	-0.403363	0.6873

D_OP(-3)	-0.000888	0.000746	-1.189427	0.2364
D_OP(-4)	0.001772	0.000650	2.724244	0.0073
OVX	-0.001904	0.000416	-4.580783	0.0000
OVX(-1)	0.000843	0.000515	1.637591	0.1039
OVX(-2)	0.000250	0.000549	0.455510	0.6495
OVX(-3)	-0.000880	0.000507	-1.735473	0.0850
OVX(-4)	0.001230	0.000402	3.063539	0.0026
D_EXR	-1.002932	1.001760	-2.666433	0.0980
D_EXR(-1)	-1.000600	1.001782	-1.336741	0.7368
D_EXR(-2)	-1.005290	1.001815	-3.915030	0.0042
D_INT	-1.001098	1.009909	-1.110798	0.9119
D_INT(-1)	0.002414	0.009814	0.246014	0.8061
D_INT(-2)	-0.029184	0.010069	-2.898313	0.0044
C	0.001704	0.018262	0.093315	0.9258
R ²	0.447070	F-value		4.888043
R ² Adjusted	0.355608	P-(F-value)		0.000000
D-W stat	1.908908			

Table 6 contains the results of short-run ARDL model by taking KSE 100 index as an independent variable. One and two period lagged values of KSE 100 index are significant while three-month-old value of KSE showing significant and negative impact on KSE 100 index. The current period values of GP and GVZ were found insignificant whereas one period lagged value of GVZ have significant impact on KSE 100 index in short-run. The current and previous three month's OP values have insignificant coefficients but the previous fourth month value found significant and positive in the short run. Only the current and 4 lagged value of OVX showing significant impact on KSE 100 index. Both variables EXR and INT are significantly impacting the KSE 100 index after two months and both have a negative impact. The fitness of the model is good as the probability of F-statistic is zero and all these studied variables are explained KSE 100 index about 35.56 percent in short-run.

5.4 F-Bounds Test

Table 7 and 8 are presented the results of ARDL F-Bounds Test by taking MCAP and KSE as dependent variables respectively. F-Bound Test assists to identify whether there is there long-run impact of independent variables on dependent variable or not.

Table 7: F-Bounds Test – Model 1

F-Bounds Test		Null Hypothesis: No levels relationship		
Test Statistic	Value	Signif.	I(0)	I(1)
			Asymptotic: n=1000	
F-statistic	15.71767	10%	1.99	2.94
K	6	5%	2.27	3.28
		2.5%	2.55	3.61
		1%	2.88	3.99

By taking value of MCAP as dependent variable in the model, F-Bounds test results is showing value of F-statistic is 15.71767 at 5 percent significance level is greater than both value of upper bound I (1) that is 3.28 and lower bound I (0) is 2.27 which confirms that there exists long-run impact of selected variables on MCAP.

Similarly taking KSE 100 index as an independent variable, the value of F-Statistic in F-Bounds test results is 20.18655 is greater than both upper bound and lower bound at 5 percent significant level. Hence there exists a long-run impact of studied regresses on KSE 100 index.

Table 8: F-Bounds Test – Model 2

F-Bounds Test		Null Hypothesis: No levels relationship		
Test Statistic	Value	Signif.	I(0)	I(1)
			Asymptotic: n=1000	
F-statistic	20.18655	10%	1.99	2.94
K	6	5%	2.27	3.28
		2.5%	2.55	3.61
		1%	2.88	3.99

5.5 ARDL Model Long-Run Results

The F-Bound Test confirmed the existence of long-run impact of selected variables on MCAP and KSE 100 index. Below table 9 and 10 contains the long-run coefficients of MCAP and KSE 100 index respectively.

Table 9: ARDL Long-Run Results – Model 1

Equation for Levels
Case 2: No Trend and Limited Constant

Undependable	Co-efficient	Norm Error	T-Value	P.*
D_GP	-7.73E-06	4.98E-05	-0.155273	0.8768
GVZ	0.001053	0.000713	1.477414	0.1418
D_OP	0.000224	0.000600	0.373037	0.7097
OVX	-0.000670	0.000250	-2.675823	0.0083
D_EXR	-0.002748	0.001398	-1.966031	0.0512
D_INT	-0.032737	0.013017	-2.514952	0.0130
C	0.015460	0.013395	1.154136	0.2504

EC = D_MCAP_LN - (-0.0000*D_GP + 0.0011*GVZ + 0.0002*D_OP -0.0007 *OVX -0.0027*D_EXR -0.0327*D_INT + 0.0155)

The table 9 demonstrated the long-run coefficients of independent variables on MCAP. In the long run only OVX and INT found significant at 5 percent level of significance. Negative values of coefficients of OVX and INT are showing negative impact on MCAP in long-run. The strength of impact of both variables is also low. The probability value of GP, GVZ, and EXR is greater than 5 percent level of significance which means these variables do not have significant impact in log-run.

Table 10: ARDL Long-Run Results – Model 2

Equation for Levels
Case 2: Limited Constant without a Trend

Undependable	Co-efficient	Norm Error	T-Value	P.*
D_GP	-3.06E-05	4.27E-05	-0.717231	0.4745
GVZ	0.001517	0.000636	2.385667	0.0185
D_OP	-0.000165	0.001097	-0.150267	0.8808
OVX	-0.000335	0.000275	-1.217186	0.2257
D_EXR	-0.006407	0.001973	-3.247809	0.0015
D_INT	-0.020235	0.013073	-1.547831	0.1240
C	0.001237	0.013239	0.093464	0.9257

EC = D_KSE_LN - (-0.0000*D_GP + 0.0015*GVZ -0.0002*D_OP -0.0003 *OVX -0.0064*D_EXR -0.0202*D_INT + 0.0012)

Table 10 is showing long-run impact of independent variables on KSE 100 index. The coefficients of GP, OP, OVX, and INT is insignificant at 5 percent level of significance. By taking KSE 100 index as independent variable, GVZ became significant and positive which was insignificant when MCAP was regressed. The variable EXR which was insignificant in previous case, also became significant in long-run when KSE 100 index used as an independent variable.

5.6. Residual Normality Test

Residual normality test is used for checking either residuals are normally distributed or not, Histogram normality test is applied for both models. Figure 2 and 3 show the results of the normality test.

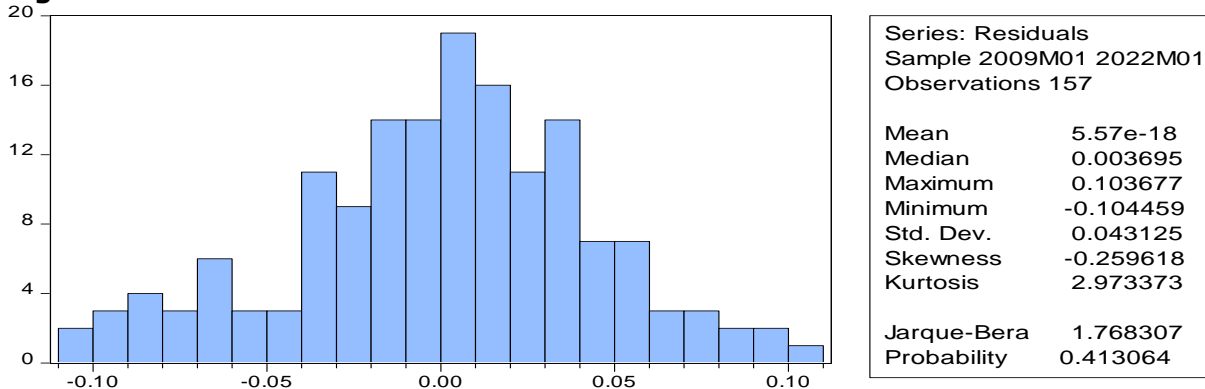
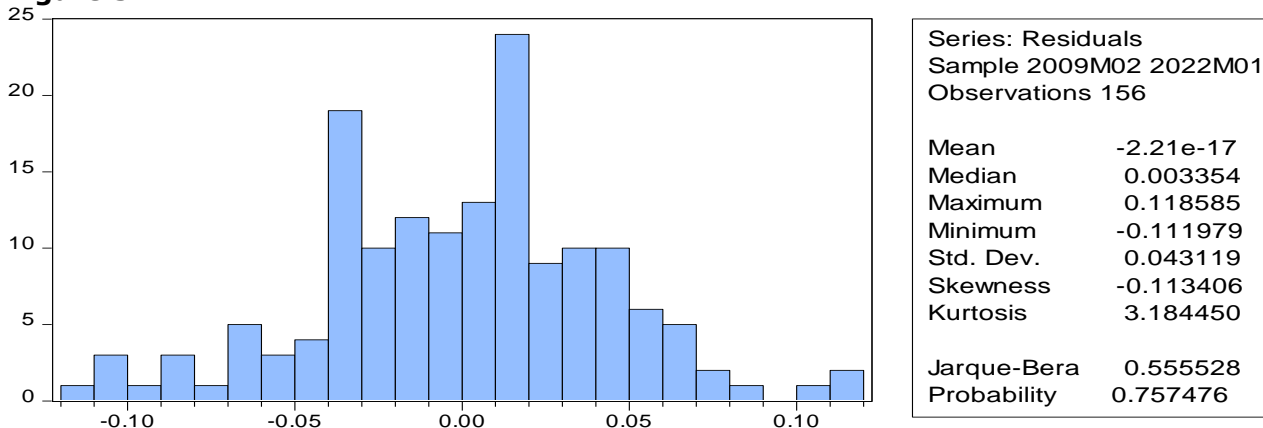
Figure 2**Figure 3**

From Histogram Normality test it can be concluded that residuals are normally distributed in both models as the Jarque-Bera probability value is bigger than the 5% criterion of significance. The short-run results obtained from ARDL model confirmed that current-period value oil volatility index (OVX) have significant and negative impact on both market capitalization and KSE 100 index and these results were in agreement with findings of (Alqahtani & Chevallier, 2020; Boateng et al., 2021; Cihangir, 2018). Thus, the impact of four-month previous value of OVX turned positive and significant KSE 100 index. One-month previous value of gold volatility index (GVZ) showed significant and positive impact on both dependent variables. The short-run coefficients of interest rate and exchange rate found insignificant and which were contrary to the findings of (Khan & Khan, 2018). However, two-month-old values of interest rate had significant impact on KSE 100 index and market capitalization. In addition, ARDL results demonstrated that only two period lagged value of exchange rate and four-month-old value of oil price had significant impact on KSE 100 index. The values of adjusted R-squared suggested that about 27 percent changes in market capitalization and 35 percent in KSE 100 index are caused by all these studied factors jointly.

The ARDL F-Bounds test results confirmed the existence of long-run impact of studied variables on both proxies of stock market as in both cases; the value of F-statistic was greater than the value of upper bound and lower bound at 5 percent significance level. The findings of long-run results of interest rate, exchange rate, and oil rates not found in agreement with the results of (Demir, 2019). The implied volatility of oil impacts the stock market as similar results were obtained by (Choi & Hong, 2020). The long-run impact of OVX and interest rate found significant and negative on MCAP at 5 percent significance level. Pakistan being an oil importing economy, changes in oil prices brings significant impact on stock market as well as on whole economy. The negative coefficients of oil volatility index in long-run and short-run are signaling that stock market of Pakistan is caused by increased uncertainty in future oil prices. The long-run coefficients of model 2 showed that gold volatility index have positive and exchange rate have negative impact on KSE 100 index at 5 percent level of significance which confirms the results of (Khan & Khan, 2018) and (Ndlovu et al., 2018).

6. Conclusion

The stock market is influenced by a number of macroeconomic factors which include prices of commodities like oil and gold, exchange rates, interest rate etc. The stock markets of under developing economies are very sensitive and react more quickly to different macroeconomic factors. This study tried to study these factors along with implied volatilities of gold and oil prices which were not studied in Pakistan's context. Monthly data from October 2008 to January 2022 was collected from reliable sources to assess the impact of these macroeconomic variables on Pakistan's stock market. Two different proxies were used for measuring performance of Pakistan Stock Exchange that were All Shares Market Capitalization and KSE 100 index of PSX. The depreciating value of Pakistani is important concern of authorities in Pakistan as listed companies heavily depend on foreign trade. The under developing economies are heavily affected by changes in international commodity prices and create adverse impact on whole economy. Especially oil importing nations like Pakistan, the volatilities and changes in oil prices create uncertain economic conditions as oil products are important input for industry different industries. In addition, rising oil prices results in increased cost of production which makes cash flows of companies uncertain, and these uncertainties are reflected in share prices which reduce the returns of investors.

References

- Ahmed, S. F., Mofijur, M., Parisa, T. A., Islam, N., Kusumo, F., Inayat, A., . . . Ong, H. C. (2022). Progress and challenges of contaminate removal from wastewater using microalgae biomass. *Chemosphere*, 286, 131656. doi:<https://doi.org/10.1016/j.chemosphere.2021.131656>
- Alqahtani, A., & Chevallier, J. (2020). Dynamic spillovers between Gulf Cooperation Council's stocks, VIX, oil and gold volatility indices. *Journal of Risk and Financial Management*, 13(4), 69. doi:<https://doi.org/10.3390/jrfm13040069>
- Aravind, M. (2018). A Scrutiny on Volatility and Leverage Effect in Indian Stock Market with Reference to Gold, Oil, Dollar Rates. *Drishtikon: A Management Journal*, 9(2), 1.
- Arfaoui, M., & Ben Rejeb, A. (2017). Oil, gold, US dollar and stock market interdependencies: a global analytical insight. *European Journal of Management and Business Economics*, 26(3), 278-293. doi:<https://doi.org/10.1108/EJMBE-10-2017-016>
- Baur, D. G., & Lucey, B. M. (2010). Is gold a hedge or a safe haven? An analysis of stocks, bonds and gold. *Financial review*, 45(2), 217-229. doi:<https://doi.org/10.1111/j.1540-6288.2010.00244.x>
- Benlagha, N. (2020). Stock market dependence in crisis periods: Evidence from oil price shocks and the Qatar blockade. *Research in International Business and Finance*, 54, 101285. doi:<https://doi.org/10.1016/j.ribaf.2020.101285>
- Bhuyan, A. K., & Dash, A. K. (2018). A dynamic causality analysis between gold price movements and stock market returns: Evidence from India. *Journal of Management Research and Analysis*, 5(2), 117-124. doi:<https://doi.org/10.18231/2394-2770.2018.0019>
- Boateng, E., Adam, A. M., & Junior, P. O. (2021). Modelling the heterogeneous relationship between the crude oil implied volatility index and African stocks in the coronavirus pandemic. *Resources policy*, 74, 102389. doi:<https://doi.org/10.1016/j.resourpol.2021.102389>
- Casson, M., & Giusta, M. D. (2007). Entrepreneurship and social capital: Analysing the impact of social networks on entrepreneurial activity from a rational action perspective. *International small business journal*, 25(3), 220-244. doi:<https://doi.org/10.1177/0266242607076524>
- Choi, S.-Y., & Hong, C. (2020). Relationship between uncertainty in the oil and stock markets before and after the shale gas revolution: Evidence from the OVX, VIX, and VKOSPI volatility indices. *PloS one*, 15(5), e0232508. doi:<https://doi.org/10.1371/journal.pone.0232508>
- Cihangir, Ç. K. (2018). The Effect of commodity volatility indexes and FED fund rates on the stock market indices of developing countries. *Muhasebe ve Finansman Dergisi (The Journal of Accounting and Finance) Forthcoming*.
- Degiannakis, S., Filis, G., & Arora, V. (2018). Oil prices and stock markets: A review of the theory and empirical evidence. *The Energy Journal*, 39(5). doi:<https://doi.org/10.5547/01956574.39.5.sdeg>
- Demir, C. (2019). Macroeconomic determinants of stock market fluctuations: The case of BIST-100. *Economies*, 7(1), 8. doi:<https://doi.org/10.3390/economies7010008>

- Diebold, F. X., & Yilmaz, K. (2012). Better to give than to receive: Predictive directional measurement of volatility spillovers. *International Journal of forecasting*, 28(1), 57-66. doi:<https://doi.org/10.1016/j.ijforecast.2011.02.006>
- Hailiang, Z., Chau, K. Y., & Waqas, M. (2023). Does green finance and renewable energy promote tourism for sustainable development: empirical evidence from China. *Renewable Energy*, 207, 660-671. doi:<https://doi.org/10.1016/j.renene.2023.03.032>
- Hou, Y., Khokhar, M., Sharma, A., Sarkar, J. B., & Hossain, M. A. (2023). Converging concepts of sustainability and supply chain networks: A systematic literature review approach. *Environmental Science and Pollution Research*, 30(16), 46120-46130. doi:<https://doi.org/10.1007/s11356-023-25412-y>
- Hou, Y., Khokhar, M., Zia, S., & Sharma, A. (2022). Assessing the Best Supplier Selection Criteria in Supply Chain Management During the COVID-19 Pandemic. *Frontiers in Psychology*, 12, 6562. doi:<https://doi.org/10.3389/fpsyg.2021.804954>
- Hung, N. T. (2020). Analysis of the time-frequency connectedness between gold prices, oil prices and Hungarian financial markets. *International Journal of Energy Economics and Policy*. doi:<https://doi.org/10.32479/ijeep.9230>.
- Irshad, M., Liu, W., Arshad, J., Sohail, M. N., Murthy, A., Khokhar, M., & Uba, M. M. (2019). A novel localization technique using luminous flux. *Applied Sciences*, 9(23), 5027. doi:<https://doi.org/10.3390/app9235027>
- Joo, Y. C., & Park, S. Y. (2021). The impact of oil price volatility on stock markets: Evidences from oil-importing countries. *Energy Economics*, 101, 105413. doi:<https://doi.org/10.1016/j.eneco.2021.105413>
- Khan, J., & Khan, I. (2018). The impact of macroeconomic variables on stock prices: a case study Of Karachi Stock Exchange. *Journal of economics and Sustainable Development*, 9(13), 15-25.
- Khaskhelly, F. Z., Khokhar, M., Zehra, N., Azhar, H., Mirza, M. H., & Raza, A. (2022). Closed Loop Supply Chain: Evaluating Ecological Footprint. *Reviews of Management Sciences*, 4(2), 69-94. doi:<https://doi.org/10.53909/rms.04.02.0195>
- Khokhar, M., Devi, A., Siddiqui, M. B., & Bhatti, A. A. (2022). Performance of the Cosmetics Industry from the Perspective of Corporate Social Responsibility and Circular Economy: A Cross? Cultural Current Challenges Faced In the Cosmetics Industry. *Pakistan Journal of Humanities and Social Sciences*, 10(4), 1571-1579-1571-1579.
- Khokhar, M., Hou, Y., Rafique, M. A., & Iqbal, W. (2020). Evaluating the social sustainability criteria of supply chain management in manufacturing industries: a role of BWM in MCDM. *Problemy Ekorozwoju*, 15(2).
- Khokhar, M., Hou, Y., Sethar, I., Amin, W., & Shakib, M. (2019). Occupational health & safety implementation framework for pakistani construction industry in Sindh province. *3C Tecnologia*, 253-284. doi:<http://dx.doi.org/10.17993/3ctecno.2019.specialissue3.253-285>
- Masih, J., Rajasekaran, R., Saini, N., & Kaur, D. (2021). Comparative Analysis of Machine Learning Algorithms for Stock Market Prediction During COVID-19 Outbreak. In *Artificial Intelligence Systems and the Internet of Things in the Digital Era: Proceedings of EAMMIS 2021* (pp. 154-161): Springer.
- Misra, P. (2018). An investigation of the macroeconomic factors affecting the Indian stock market. *Australasian Accounting, Business and Finance Journal*, 12(2), 71-86. doi:<http://dx.doi.org/10.14453/aabfj.v12i2.5>
- Mollick, A., & Nguyen, K. H. (2015). US oil company stock returns and currency fluctuations. *Managerial Finance*, 41(9), 974-994. doi:<https://doi.org/10.1108/MF-02-2014-0029>
- Mothafar, N. A., Zhang, J., & Al-Maqrami, I. (2022). The evolution of human development through the eyes of ICT in developing countries based on panel data from 2007 to 2017. *Indian Journal of Human Development*, 16(3), 578-601. doi:<https://doi.org/10.1177/09737030221146021>
- Ndlovu, B., Faisa, F., Resatoglu, N. G., & Türsoy, T. (2018). The Impact Macroeconomic Variables on Stock Returns: A Case of the Johannesburg Stock Exchange. *Romanian Statistical Review*(2).
- Omodero, C. O., & Mlenga, S. (2019). Evaluation of the impact of macroeconomic variables on stock market performance in Nigeria. *Business and Management Studies*, 5(2), 34-44. doi:<https://doi.org/10.11114/bms.v5i2.4208>

- Qasim, T. B., Iqbal, G. Z., Hassan, M. U., & Ali, H. (2021). Application of Markov Regime Switching Autoregressive Model to Gold Prices in Pakistan. *Review of Economics and Development Studies*, 7(3), 309-323. doi:<https://doi.org/10.47067/reads.v7i3.368>
- Raza, N., Shahzad, S. J. H., Tiwari, A. K., & Shahbaz, M. (2016). Asymmetric impact of gold, oil prices and their volatilities on stock prices of emerging markets. *Resources policy*, 49, 290-301. doi:<https://doi.org/10.1016/j.resourpol.2016.06.011>
- Shrestha, M. B., & Bhatta, G. R. (2018). Selecting appropriate methodological framework for time series data analysis. *The Journal of Finance and Data Science*, 4(2), 71-89. doi:<https://doi.org/10.1016/j.jfds.2017.11.001>
- Siddiqui, M. B., Khokhar, M., Makhdoom, T. R., Devi, A., Bhatti, A. A., & Hussain, N. (2023). Exploring the Rural Development of China Pakistan Economic Corridor Project Impact on Social Responsibilities and South Region of Pakistan. *International Journal of Special Education*, 38(1).
- Singhal, S., Choudhary, S., & Biswal, P. C. (2019). Return and volatility linkages among International crude oil price, gold price, exchange rate and stock markets: Evidence from Mexico. *Resources policy*, 60, 255-261. doi:<https://doi.org/10.1016/j.resourpol.2019.01.004>
- Syed, Q. R., & Bouri, E. (2022). Spillovers from global economic policy uncertainty and oil price volatility to the volatility of stock markets of oil importers and exporters. *Environmental Science and Pollution Research*, 1-11. doi:<https://doi.org/10.1007/s11356-021-16722-0>
- Usman, M., & Siddiqui, D. A. (2019). The effect of oil price on stock market returns with moderating effect of foreign direct investment & foreign portfolio investment: evidence from Pakistan stock market. *Usman, M. and Siddiqui, DA (2019). The Effect of Oil Price on Stock Market Returns with Moderating Effect of Foreign Direct Investment & Foreign Portfolio Investment: Evidence from Pakistan Stock Market. Asian Journal of Economic Modelling*, 7(2), 45-61.
- Vveinhardt, J., Streimikiene, D., Ahmed, R., Ghauri, S., & Ashraf, M. (2017). Asymmetric influence of oil and gold prices on Baltic and South Asian stock markets: Evidence from Johansen cointegration and ARDL approach. *Acta Montanistica Slovaca*, 22(4), 422-438.
- Waseem, A., Khokhar, M., Zia, S., & Hou, Y. Republic, C.(2022). *Supply Chain Management in Crisis: Agile Planning to Avoid Supply Chain Disasters*, 13(6), 422-441.
- Yumei, H., Iqbal, W., Irfan, M., & Fatima, A. (2021). The dynamics of public spending on sustainable green economy: role of technological innovation and industrial structure effects. *Environmental Science and Pollution Research*, 1-19. doi:<https://doi.org/10.1007/s11356-021-17407-4>